



# Standard Test Method for Rubber Property—Plasticity and Recovery (Parallel Plate Method)<sup>1</sup>

This standard is issued under the fixed designation D926; the number immediately following the designation indicates the year of original adoption or, in the case of revision, the year of last revision. A number in parentheses indicates the year of last reapproval. A superscript epsilon ( $\epsilon$ ) indicates an editorial change since the last revision or reapproval.

*This standard has been approved for use by agencies of the U.S. Department of Defense.*

## 1. Scope

1.1 This test method covers the determination of plasticity and recovery of unvulcanized rubber by means of the parallel plate plastometer. Uncompounded, compounded, and reclaim rubber may be tested.

NOTE 1—ISO 2007 and Test Method D3194 use a principle similar to this test method although the apparatus, test conditions, and procedure are different.

1.2 The values stated in SI units are to be regarded as standard. No other units of measurement are included in this standard.

1.3 *This standard does not purport to address all of the safety concerns, if any, associated with its use. It is the responsibility of the user of this standard to establish appropriate safety and health practices and determine the applicability of regulatory limitations prior to use.*

## 2. Referenced Documents

### 2.1 ASTM Standards:<sup>2</sup>

D3194 Test Method for Rubber From Natural Sources—Plasticity Retention Index (PRI)

D3767 Practice for Rubber—Measurement of Dimensions

D4483 Practice for Evaluating Precision for Test Method Standards in the Rubber and Carbon Black Manufacturing Industries

E145 Specification for Gravity-Convection and Forced-Ventilation Ovens

### 2.2 ISO Standard:<sup>3</sup>

ISO 2007 Rubber Unvulcanized—Determination of Plasticity—Rapid Plastimeter Method

<sup>1</sup> This test method is under the jurisdiction of ASTM committee D11 on Rubber and is the direct responsibility of Subcommittee D11.12 in Processability Tests.

Current edition approved Nov. 1, 2013. Published January 2014. Originally approved in 1956. Last previous edition approved in 2008 as D926–08. DOI: 10.1520/D0926-08R13.

<sup>2</sup> For referenced ASTM standards, visit the ASTM website, [www.astm.org](http://www.astm.org), or contact ASTM Customer Service at [service@astm.org](mailto:service@astm.org). For *Annual Book of ASTM Standards* volume information, refer to the standard's Document Summary page on the ASTM website.

<sup>3</sup> Available from American National Standards Institute, 25 West 43rd St., 4th Floor, New York, NY 10036.

## 3. Summary of Test Method

### 3.1 Plasticity:

3.1.1 A specimen of specific volume and height is tested at room temperature or heated to a specified test temperature for 15 min and then subjected to a compressive force of 49 N for a specified time.

3.1.2 At the end of this time, the height of the specimen is measured, and the plasticity number is calculated.

### 3.2 Recovery—There are two recovery procedures.

3.2.1 *Procedure A*—The test specimen is removed from the plastometer immediately after the determination of plasticity and allowed to cool and recover some of its original height for 1 min. The height is measured again and the recovery is calculated.

3.2.2 *Procedure B*—The test specimen is compressed to a height of 5 mm for 30 s and then allowed to recover at the test temperature for 5 min. The height is measured again and the recovery is calculated.

## 4. Significance and Use

4.1 The plasticity number and the recovery of the test specimen are related to the flow properties and the elastic properties, respectively, and may be useful in predicting processing characteristics, such as ease of forming and extrusion characteristics.

4.1.1 In this test method, plasticity is measured in an inverse manner, as noted by the final height of the specimen. Thus, high plasticity rubbers (high degree of flow during test) are indicated by a low plasticity number.

## 5. Apparatus

5.1 The essential features of the parallel plate plastometer, illustrated in Fig. 1, are as follows:

5.1.1 Two metal plates, not less than 10 mm in thickness and 40 mm in diameter, shall be mounted on a suitable frame so that one plate moves with respect to the other, and so that the two plates are parallel within 0.017 rad (1°) at all times.

5.1.2 The apparatus shall be so designed that a specimen between the parallel plates is subjected to a force of  $49 \pm 0.5$  N, including the effect of the spring in the dial gauge during test.

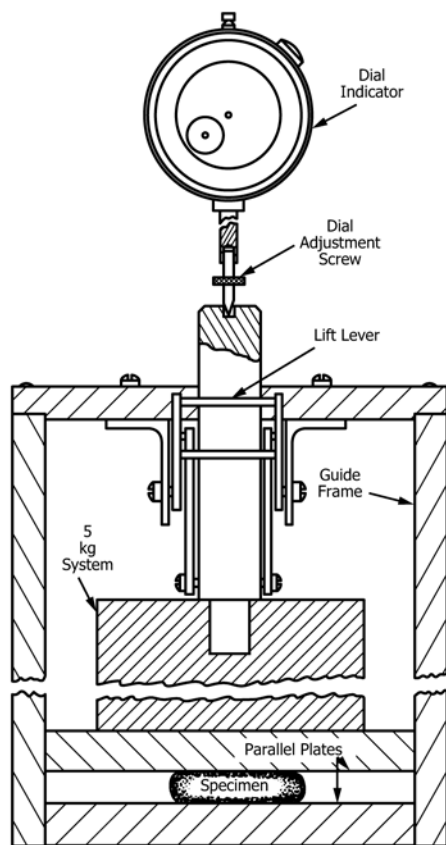

FIG. 1 One Type of Parallel Plate Plastometer

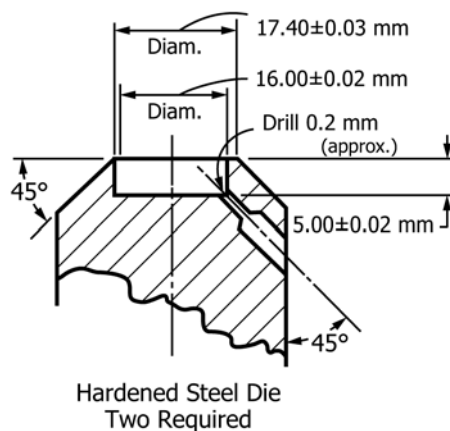

FIG. 2 Die for Forming Test Specimen

may be prepared from either a solid piece or plied sheets of unvulcanized rubber approximately 1.5 mm in thickness, care being taken to exclude air pockets in the sheet. The specimens may be cut from the sheet either by means of two mating dies conforming to Fig. 2, which produce cylinders of the correct volume, or a rotating die having an internal diameter of approximately 16 mm. If a rotating die is used, the height of the cylinder shall be adjusted until the volume is  $2.00 \pm 0.02 \text{ cm}^3$ . If the density is known, weighing may be used to adjust to the correct volume. If necessary, the specimen shall be placed in a suitable holder so that it is not appreciably deformed before testing.

5.1.3 A digital or dial indicator gauge calibrated in hundredths of a millimetre (0.01 mm) shall be mounted on the apparatus in such a manner that the distance between the plates can be determined at all times.

5.1.4 When required, the apparatus shall be operated in any oven, as described in Specification E145, that is capable of containing the plastometer.

5.1.5 A separate dimensional measurement gauge is required for performing recovery measurements. The apparatus and methodology described in Practice D3767, Procedure A, shall be employed when performing these measurements.

5.2 *Test Surfaces*—Films or material with low coefficients of friction shall be used to prevent sticking of the test specimen to the plates. The most commonly used test surface is polyester film. Other films such as cellophane or nylon may be used. The test surface film shall have a thickness of  $0.25 \pm 0.005 \text{ mm}$ .

NOTE 2—The test surface used can affect the plasticity number. Even different grades of the same type of film can cause different results. When comparing results, the same test surface must be used.

## 6. Sampling

6.1 Samples may be taken from raw rubber or unvulcanized rubber compounds undergoing processing operations.

## 7. Test Specimens

7.1 The specimen shall be a right cylinder  $2.00 \pm 0.02 \text{ cm}^3$  in volume and be free from air pockets. (A cylinder 16 mm in diameter and 10 mm in height is appropriate.) The specimen

## 8. Test Conditions

8.1 The plasticity and recovery values obtained for a given sample will depend largely upon the manner in which the test specimen is prepared. It is therefore imperative that when comparisons are made between similar materials, the test specimen preparation should be in accordance with some rigidly specified method. This is necessary because the plasticity and recovery may be affected by the amount of mechanical working and the conditions under which such work is done. This effect is not constant for all materials. The time interval between test specimen preparation and testing is important and should be the same for test specimens between which comparisons are to be made.

8.2 The test temperature shall be 23 (room temperature), 40, 70, 85, or 100°C unless another temperature is agreed upon. The most frequently used temperature is 23°C.

8.3 Readings may be taken at any desired interval following the application of the load. The most frequently used intervals are between 3 and 10 min.

## 9. Plasticity Procedure

9.1 Set the indicator to read zero with two thicknesses of the test surface between the plates. Condition the plastometer at the test temperature until temperature equilibrium is achieved.

9.2 Place the test specimen between the two test surfaces to prevent sticking of the test specimen to the plates.